

A-GEAR Product Specification

Single Fiber Bi-directional SFP Transceiver SFP-ISM-40SC

PRODUCT FEATURES

- Up to 1.25 Gb/s bi-directional data links
- Hot-pluggable SFP footprint
- 1310nm DFB Transmitter and 1550nm PIN Receiver for SFP-ISM-1310nm-40SC
- 1550nm DFB Transmitter and 1310nm PIN Receiver for SFP-ISM-1550nm-40SC
- Single SC connector
- Low power dissipation
- Built-in digital diagnostic functions
- Metal enclosure, for lower EMI
- Up to 40km point to point transmission
- Single 3.3V power supply
- Operating temperature range: -40°C to 85°C

APPLICATIONS

Ethernet

Point-to-point FTTX Application

PRODUCT SELECTION

Absolute Maximum Ratings

Parameter	Symbol	Min	Typ	Max	Unit	Ref.
Maximum Supply Voltage	Vcc	-0.5		4.7	V	
Storage Temperature	TS	-40		85	°C	
Case Operating Temperature	TOP	-40		85	°C	

Electrical Characteristics (TOP = -40 to 85°C, VCC = 3.15 to 3.60Volts)

Parameter	Symbol	Min	Typ	Max	Unit	Ref.
Supply Voltage	Vcc	3.15	3.3	3.6	V	
Supply Current	Icc		185	250	mA	
Transmitter						
Input differential impedance	Rin		100		Ω	1
Single ended data input swing	Vin,pp	250		1200	mV	
Transmit Disable Voltage	VD	Vcc- 1.3		Vcc	V	
Transmit Enable Voltage	VEN	Vee		Vee+ 0.8	V	2



Transmit Disable Assert Time				10	us	
Receiver						
Single ended data output swing	Vout,pp	250		800	mV	3
Data output rise time	tr		100	175	ps	4
Data output fall time	tf		100	175	ps	4
LOS Fault	VLOS fault	Vcc-0.5		VccHOST	V	5
LOS Normal	VLOS norm	Vee		Vee+0.5	V	5
Power Supply Rejection	PSR	100			mVpp	6

Notes:

1. Connected directly to TX data input pins. AC coupled thereafter.
2. Or open circuit.
3. Into 100 ohms differential termination.
4. 20 – 80 %
5. Loss Of Signal is LVTTTL. Logic 0 indicates normal operation; logic 1 indicates no signal detected.
6. Receiver sensitivity is compliant with power supply sinusoidal modulation of 20 Hz to 1.5 MHz up to specified value applied through the recommended power supply filtering network.

Optical Characteristics (TOP = -40 to 85°C, VCC = 3.15 to 3.60 Volts)

SFP-1SM-1310nm-40SC

Parameter	Symbol	Min	Typ	Max	Unit	Ref.
Transmitter						
Output Opt. Pwr (End of Life)	POUT	-5.0		0	dBm	1
Optical Wavelength	λ	1270	1310	1360	nm	
Wavelength Temperature Dependance			0.08	0.125	nm/°C	
Spectral Width (-20dB)	σ			3.0	nm	
Optical Extinction Ratio	ER	8			dB	
Sidemode Supression ratio	SSRmin	30			dB	
Optical Rise/Fall Time	tr/ tf		100	160	ps	
RIN	RIN			-120	dB/Hz	
Transmitter Jitter (peak to peak)				100	ps	
Receiver						
Average Rx Sensitivity @ 1.25G	RSSENS3			-25.0	dBm	2
Maximum Input Power	PMAX	-3.0			dBm	
Optical Center Wavelength	λC	1530	1550	1570	nm	
LOS De -Assert	LOSD			-30	dBm	
LOS Assert	LOSA	-35			dBm	
LOS Hysteresis		0.5		4	dB	
Receiver Jitter Generation @1.25Gbps				160	ps	3

SFP-1SM-1550nm-40SC

Parameter	Symbol	Min	Typ	Max	Unit	Ref.
Transmitter						



Output Opt. Pwr (End of Life)	POUT	-5.0		0	dBm	1
Optical Wavelength	λ	1540	1550	1560	nm	
Wavelength Temperature Dependence			0.08	0.125	nm/°C	
Spectral Width (-20dB)	σ			3.0	nm	
Optical Extinction Ratio	ER	8			dB	
Sidemode Supression ratio	SSRmin	30			dB	
Optical Rise/Fall Time	tr/ tf		100	160	ps	
RIN	RIN			-120	dB/Hz	
Transmitter Jitter (peak to peak)				100	ps	
Receiver						
Average Rx Sensitivity @1.25G	RSENS3			-25.0	dBm	2
Maximum Input Power	PMAX	-3.0			dBm	
Optical Center Wavelength	λC	1260	1310	1360	nm	
LOS De -Assert	LOSD			-30	dBm	
LOS Assert	LOSA	-35			dBm	
LOS Hysteresis		0.5		4	dB	
Receiver Jitter Generation @1.25Gbps				160	ps	3

Notes:

1. Class 1 Laser Safety per FDA/CDRH and IEC-825-1 regulations.
2. With worst-case extinction ratio. Measured with a PRBS 2⁷-1 test pattern, @1.25Gb/s, BER<10⁻¹².
3. Jitter added by receiver (peak to peak). Measured at -18.0dBm average Rx sensitivity, PRBS 2⁷-1 test pattern.

PRODUCT SELECTION

Pin Descriptions

Pin	Symbol	Name/Description	Ref.
1	V _{EET}	Transmitter Ground (Common with Receiver Ground)	1
2	T _{FAULT}	Transmitter Fault.	2
3	T _{DIS}	Transmitter Disable. Laser output disabled on high or open.	3
4	MOD_DEF(2)	Module Definition 2. Data line for Serial ID.	4
5	MOD_DEF(1)	Module Definition 1. Clock line for Serial ID.	4
6	MOD_DEF(0)	Module Definition 0. Grounded within the module.	4
7	Rate Select	No connection required	
8	LOS	Loss of Signal indication. Logic 0 indicates normal operation.	5
9	V _{EER}	Receiver Ground (Common with Transmitter Ground)	1
10	V _{EER}	Receiver Ground (Common with Transmitter Ground)	1
11	V _{EER}	Receiver Ground (Common with Transmitter Ground)	1
12	RD-	Receiver Inverted DATA out. AC Coupled	
13	RD+	Receiver Non-inverted DATA out. AC Coupled	
14	V _{EER}	Receiver Ground (Common with Transmitter Ground)	1
15	V _{CCR}	Receiver Power Supply	

16	V _{CCT}	Transmitter Power Supply	
17	V _{EET}	Transmitter Ground (Common with Receiver Ground)	1
18	TD+	Transmitter Non-Inverted DATA in. AC Coupled.	
19	TD-	Transmitter Inverted DATA in. AC Coupled.	
20	V _{EET}	Transmitter Ground (Common with Receiver Ground)	1

Notes:

1. Circuit ground is internally isolated from chassis ground.
2. T_{FAULT} is an open collector/drain output, which should be pulled up with a 4.7k – 10k Ohms resistor on the host board if intended for use. Pull up voltage should be between 2.0V to Vcc + 0.3V. A high output indicates a transmitter fault caused by either the TX bias current or the TX output power exceeding the preset alarm thresholds. A low output indicates normal operation. In the low state, the output is pulled to <0.8V.
3. Laser output disabled on T_{DIS} >2.0V or open, enabled on T_{DIS} <0.8V.
4. Should be pulled up with 4.7k - 10 kohms on host board to a voltage between 2.0V and 3.6V. MOD_DEF(0) pulls line low to indicate module is plugged in.
5. LOS is open collector output. Should be pulled up with 4.7k – 10 kohms on host board to a voltage between 2.0V and 3.6V. Logic 0 indicates normal operation; logic 1 indicates loss of signal.

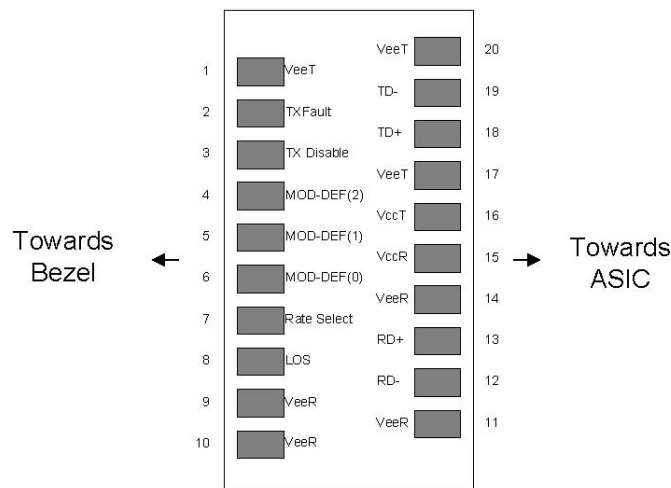

Pinout of Connector Block on Host Board

Digital Diagnostic Functions

1SM-1310(1550)nm-40SC 12-40DA transceivers support the 2-wire serial communication protocol as defined in the SFP MSA₁. It is very closely related to the EEPROM defined in the GBIC standard, with the same electrical specifications.

The standard SFP serial ID provides access to identification information that describes the transceiver’s capabilities, standard interfaces, manufacturer, and other information.

Additionally, A-GEAR SFP transceivers provide a unique enhanced digital diagnostic monitoring interface, which allows real-time access to device operating parameters such as transceiver temperature, laser bias current, transmitted optical power, received optical power and transceiver supply voltage. It also defines a sophisticated system of alarm and warning flags, which alerts end-users when particular operating



parameters are outside of a factory set normal range.

The SFP MSA defines a 256-byte memory map in EEPROM that is accessible over a 2-wire serial interface at the 8 bit address 1010000X (A0h). The digital diagnostic monitoring interface makes use of the 8 bit address 1010001X (A2h), so the originally defined serial ID memory map remains unchanged. The interface is identical to, and is thus fully backward compatible with both the GBIC Specification and the SFP Multi Source Agreement.

The operating and diagnostics information is monitored and reported by a Digital Diagnostics Transceiver Controller (DDTC) inside the transceiver, which is accessed through a 2-wire serial interface. When the serial protocol is activated, the serial clock signal (SCL, Mod Def 1) is generated by the host. The positive edge clocks data into the SFP transceiver into those segments of the E2PROM that are not write-protected. The negative edge clocks data from the SFP transceiver. The serial data signal (SDA, Mod Def 2) is bi-directional for serial data transfer. The host uses SDA in conjunction with SCL to mark the start and end of serial protocol activation. The memories are organized as a series of 8-bit data words that can be addressed individually or sequentially.

Digital diagnostics for the SFP-1SM-40SC 12-40DA are Internally calibrated by default.

Mechanical Specifications

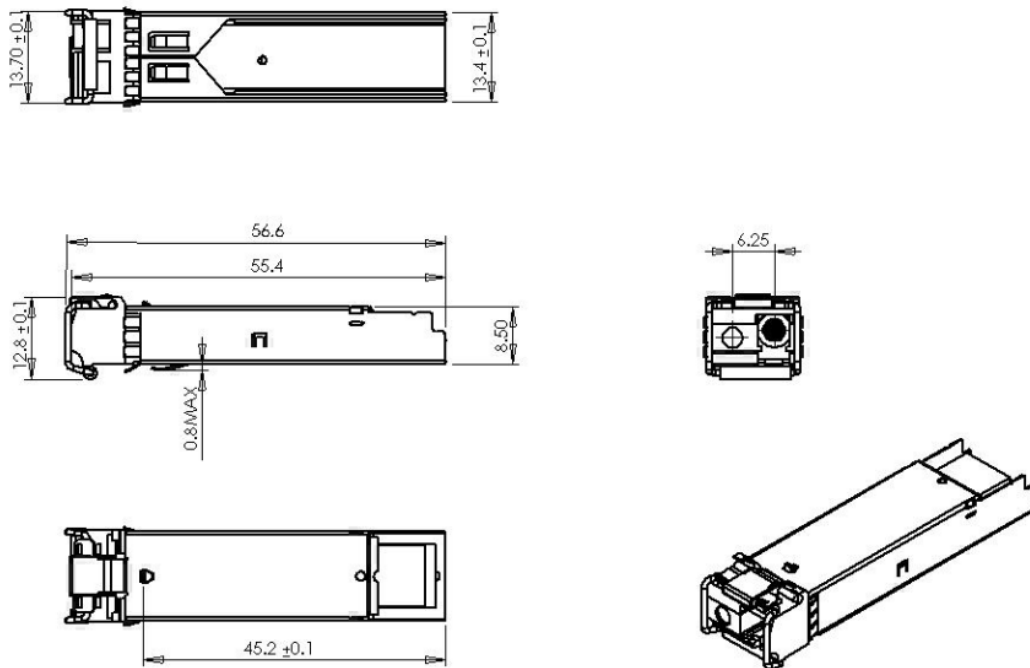

Visual look

